

# Heat Exchanger

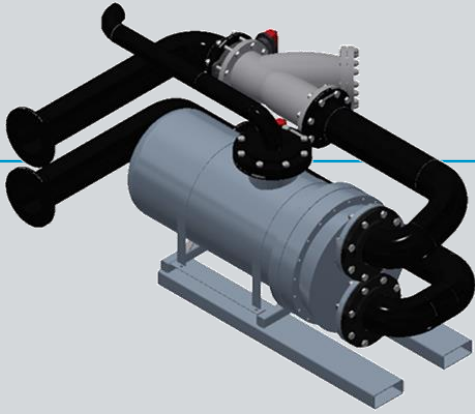

**HX-1400**

## Features:

- Frame-mounted shell and tube heat exchanger
- Steam to hydronic hot water transfer
- Pre-installed steam valving ready for use

## General Information

<b>Rental Category</b>	Heat Exchanger
<b>Unit Design</b>	RH Internal
<b>Heat Exchanger Design</b>	Shell and Tube
<b>Use Type</b>	Steam – Water

## Specifications and Requirements

<b>Usable Surface Area</b>	194 ft <sup>2</sup> (18 m <sup>2</sup> )
<b>Design Pressure – Shell</b>	150 PSIG (10.3 BARG)
<b>Feedwater Output Flow</b>	150 PSIG (10.3 BARG)
<b>Max Flow (Tube)</b>	1,400 GPM (5,300 LPM)
<b>Electricity</b>	120 V / 3 Phase / 20 A @ 60 Hz

## Connections

<b>Steam (Input)</b>	4" 150# FLG
<b>Condensate (Output)</b>	2" NPT
<b>Water Supply (Output)</b>	6" 150# FLG
<b>Water Supply (Input)</b>	6" 150# FLG

## Dimensions

<b>Overall Length</b>	06' 06" (2 M)
<b>Overall Width</b>	06' (1.8 M)
<b>Overall Height</b>	05' (1.5 M)
<b>Shipping Weight</b>	1,500 LBS (680 KGS)

Last updated on: 17-Dec-24



**Atlas Copco**  
**Rental**  
Making Agility Count

**Atlas Copco Rental**

[www.atlascopcorental.com](http://www.atlascopcorental.com)

Subject to change without prior notice. Information is for guidance only.  
Please contact your nearest Rental office for detailed application advice.